



42" diameter version
shown in Textured Bronze



52" diameter version
shown in Polished Chrome

Irene-3H

Designed in 2013



52" diameter version shown in Brushed Nickel

Cutting a figure like no other, the Irene-3H rodless-style fan, is rustic, yet strikingly modern with three neatly joined, solid walnut-stained wooden blades. A cylindrical motor housing complements its minimal profile. Irene-3H is streamline while still appearing warm and natural.

- Three solid wood, walnut-stained machine-cut blades in 42" or 52" diameters.
- Energy efficient, ultra-quiet, six-speed and reversible DC motor with new, reliable technology.
- Damp location finishes: brushed nickel, polished chrome, textured bronze, matte black and gloss white.
- Reverse on hand-held, wall mountable six-speed remote control.
- Constructed of cast aluminum and heavy stamped steel.
- Limited Lifetime Warranty



MATTHEWS

FAN COMPANY



Irene-3H

weight: 11 lbs

voltage: 110*

*Please contact us for possible 220 conversion

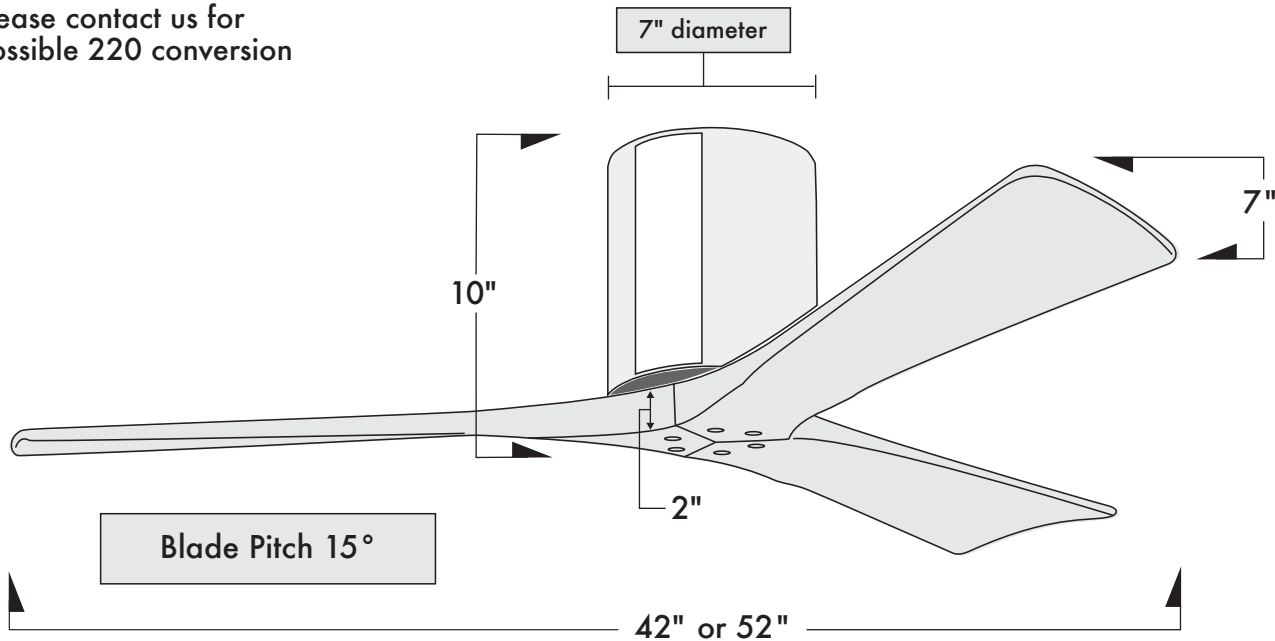

SKU Naming Convention	
IR3H-XX-XX (Model-Finish-Diameter)	
Finishes	Diameter
Gloss White - WH	42" - 42
Matte Black - BK	52" - 52
Brushed Nickel - BN	
Polished Chrome - CR	
Textured Bronze - TB	

CFM
42" Diameter - 4033
52" Diameter - 6140



The Irene-3H is compatible with a proprietary decora-style accessory wall control: DC-WC.



**Damp location: All standard finishes. Not recommended for salt water / ocean front applications.