

Waste Force Food Disposer

Model WF-200

10 Years Warranty



¾ hp/560 Watts



Waste Force disposal units use the MaxForce grinding system and premium quality components to create the ultimate home waste disposal system to give years of faultless high performance:

- 4,000 rpm starting speed permanent-magnet motor to eliminate clogging, binding and jamming.
- Acoustically balanced stainless steel turntable and armature for smooth, quiet operation.
- Aerospace Soundsure Insulation.
- Stainless steel impellers for long life and performance.
- Removable splash guard for easy cleaning.
- MountMaster locking system for quick and easy installation.
- Corrosion proof 7/8" dishwasher inlet with ko plug.
-

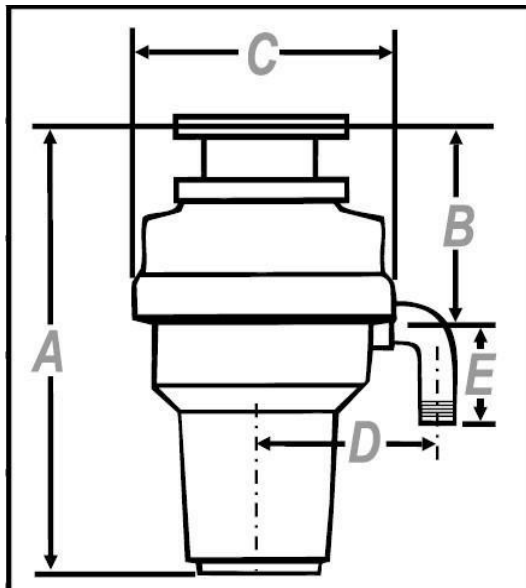

Specifications	Model WF-200	
Power	¾ hp 560 Watts	
Motor Start Speed	4,000 rpm	
Operating Speed	2,800 rpm	
Voltage	220-240V	
Current	2.3 Amp	
Hertz	50/60 Hz	
Motor Type	Permanent Magnet	
Splash Guard	PVC	
Drain Outlet	Polycarbonate 940	
Grind Ring	Stainless Steel	
Swivel Impellers	Stainless Steel Cast	
Balanced Turntable	Stainless Steel	
Balanced Armature Shaft	Stainless Steel	
Hopper	Polycarbonate 940	
Insulation	Aerospace Soundsure	
Drain Housing	Phenolic EA-5551J	
Circuit Overload Protector	Manual Reset Breaker	
Sink Flange	Polycarbonate 940	
Mounting System	Easy-fit MountMaster	
Stopper	ABS	
Bearings	Permanent Sealed Sleeve	
Sound Insulation on Shell	Full	
Individual Shipping Weight	5.9 kg	
Measurement A	406 mm	
Measurement B	184 mm	
Measurement C	218 mm	
Measurement D	142mm White Elbow	147mm Black Elbow
Measurement E	70mm White Elbow	100mm Black Elbow
Grinding System	MaxForce	
Chamber Capacity	1000 ml	
Corrosion Warranty	Lifetime	
Warranty	10 Years	

Waste Force – Exclusive Global Distributors

© 2014 The Henley Fan Company Ltd, Unit 1
 22 Harrison Close, Twyford, England, RG10 0LL
 Tel: 01256 636 509 sales@henleyfan.com
 www.waste-force.com www.henleyfan.com